

FlowMatic® 01



01

Rate: 10 to 20 big bags/hr.
Weight capacity: 2 tons/big bag
Objectives: cost efficient & dust containment

TECHNICAL SPECIFICATIONS

Rate: 10 to 20 big bags/hr.
Manufacturing materials: mild steel, SS 304L, SS 316L
Finishes: RAL 9006, micro-blasted, electropolishing
Installed power: 0.2 kW
Compressed air consumption: 0.1 Nm³/h.
Service pressure: 6 bars
Input TOR: 0
Output TOR: 1
Dust collecting rate: 300 m³/hr.
Maximum dimensions of big bags:
Length x width x height: 1.550 x 1.550 x 2.400 mm
"U" version forks: allows big bag removal with straps (optional)

OPERATING SEQUENCE

1. The big bag is placed on the filling station
2. The big bag inlet is connected to the filling head by an inflatable gasket ensuring the sealing
3. Big bag filling process
4. When the big bag filling sequence is completed, the big bag can then be removed using either a forklift or a pallet truck



Adjustable fork height for an optimal filling of all types of big bags



Double envelope filling head allows big bag degassing in conditioning procedure



Hooking forks with adjustable height offer a maximum flexibility

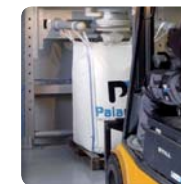

Big bag removal with forklift or pallet truck

Advantages

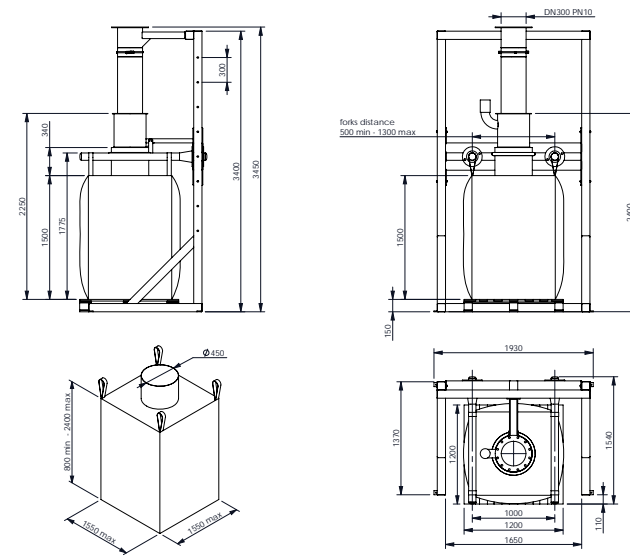

Options

- Big bag pre-forming fan
- Big bag tension cylinder