

BIG BAG SOLUTIONS

Big Bag and Sack Compactor

Mild steel and 304 stainless steel construction

Suitable for food-processing and pharmaceutical applications

Reduces waste and maintains a healthy, dust-free environment



This machine is intended for compacting all types of sacks and big bags while eliminating dust by extruding the sacks in an air-tight polyethylene tube. Compactors may be independent or integrated into unpacking units.

TECHNICAL FEATURES:

2 models: Big Bag Compactor and Sack Compactor

The compactor is composed of a screw activated by a 2.2 kW gearmotor.

430 mm Ø tubing compacts the sacks / big bags.

The sacks / big bags are extruded into a plastic tube held by 2 elastic rings.

Confinement is total.

Operating procedure:

The operator places the empty sacks in the compactor's protective casing through an access hatch.

An autonomous control unit allows him to start and stop the compactor.



Installations



Independent Big Bag Compactor

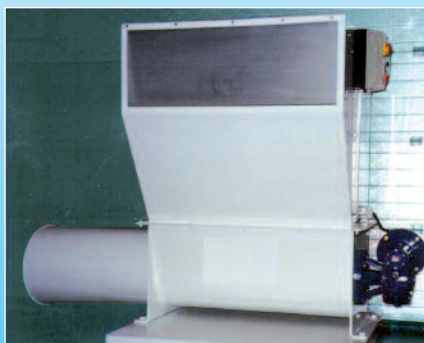

Independent Sack Compactor



Sack compactor integrated with a manual sack opening machine



Sack compactor integrated with an automated sack opening machine



BIG BAG COMPACTOR DIMENSIONS

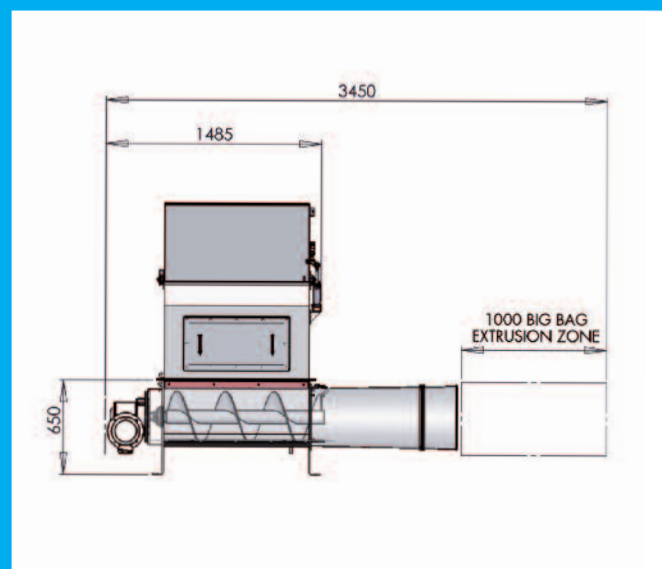
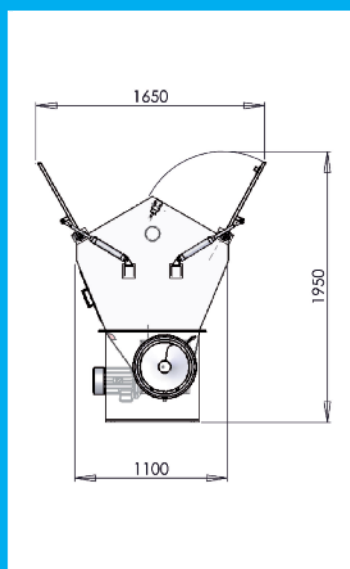
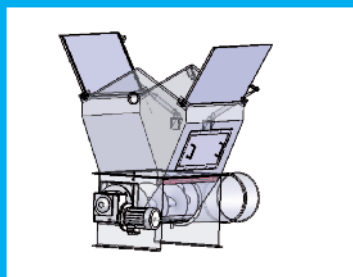
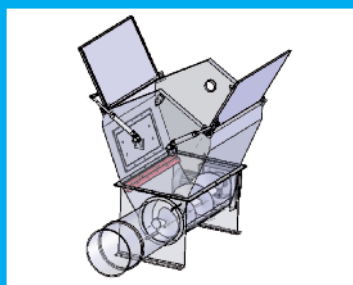

■ BIG BAG PRESS

This compactor is composed of an entirely shrouded frame protecting the operator and providing confinement for pressing big bags. The compactor is opened by two pneumatic cylinders.

SACK COMPACTOR DIMENSIONS

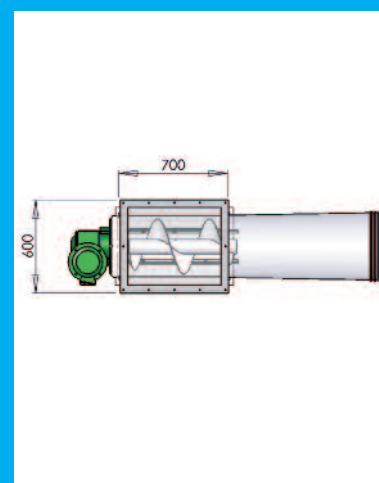
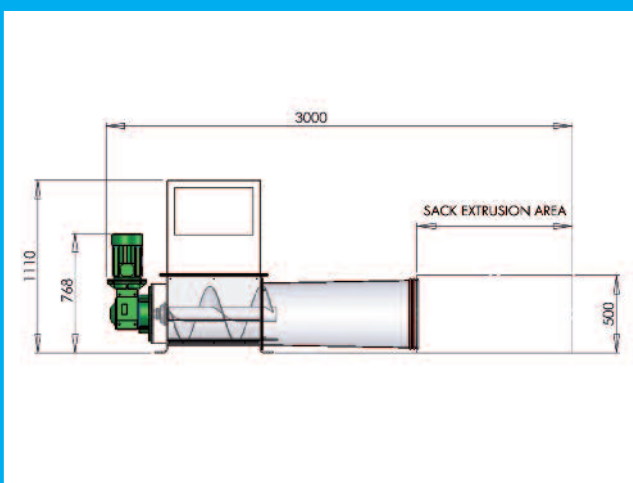
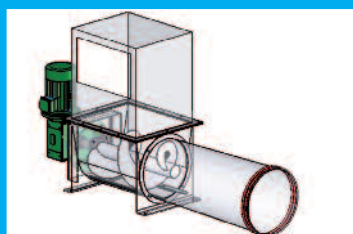
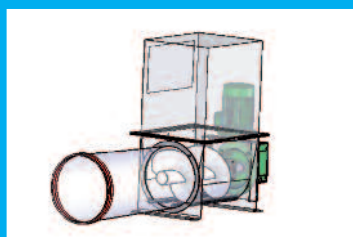

OPTIONS

■ DUST COLLECTION

Compactors may be integrated into a dust collection grid in order to maintain a healthy atmosphere.

■ MOBILE SYSTEM

Compactors may be installed on manoeuvring for use at various workstations.

Advantages:

- Suitable for all types of big bags and sacks: paper, plastic, jute canvas...
- Clean working environment

- Stand-alone or integrated in a sack / big bags emptying system
- Fines residues can be recovered in a specific tray

For further information: www.palamaticprocess.com

Rue de l'Ecotais • Z.A. de La Croix Rouge • 35530 BRÉCÉ
Tél. : +33 (0)2 99 86 06 22 • Fax : +33 (0)2 99 86 08 10

